

CHB150-110S

S E R I E S

150 WATT

DC-DC CONVERTERS



Features

- 150W Isolated Output
- Efficiency to 92.5%
- 200KHz Switching Frequency
- 3 : 1 Input Range
- Regulated Outputs
- Remote ON/OFF
- Over Temperature Protection
- Over Voltage/Current Protection
- Continuous Short Circuit Protection
- Half Brick Size Meet Industrial Standard
- CE Mark Meets 2004/108/EC
- UL60950-1 Approval
- Meet EN50155 With External Circuits

MODEL NUMBER	INPUT VOLTAGE	OUTPUT VOLTAGE	OUTPUT CURRENT		INPUT CURRENT		% EFF.	Capacitor Load max.
			MIN.	MAX.	NO LOAD	FULL LOAD		
CHB150-110S05	66-160 VDC	5.0 VDC	0 mA	30 A	40 mA	1474 mA	92.5	10000µF
CHB150-110S12	66-160 VDC	12 VDC	0 mA	12.5 A	40 mA	1474 mA	92.5	5600µF
CHB150-110S24	66-160 VDC	24 VDC	0 mA	6.5 A	60 mA	1541 mA	92	2200µF

NOTE: 1. Nominal Input Voltage 110VDC

Remote ON/OFF Control

The CHB series allows the user to switch the module on and off electronically by remote on/off feature. The CHB series are available in "positive logic" or "negative logic" (option) versions.

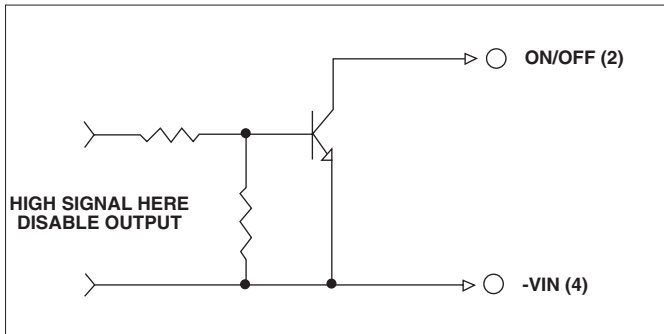

Logic Table

Logic State (Pin 2)	Negative Logic	Positive Logic
Logic Low - Switch Closed	Module on	Module off
Logic High - Switch Open	Module off	Module on

External Output Trimming

Output may optionally be Externally trimmed ($\pm 10\%$) with a fixed resistor or an external trimpot as shown.

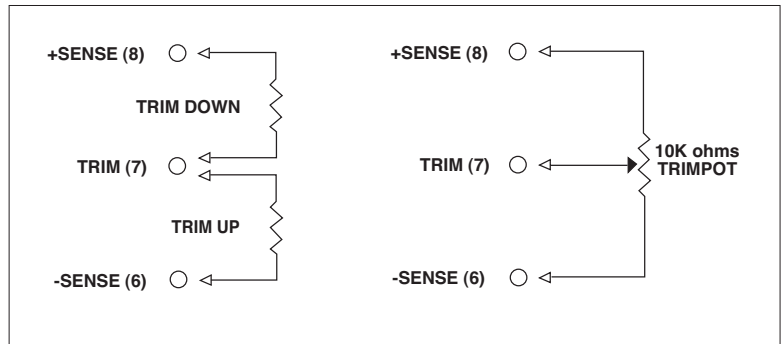

External Output

Output Ripple and Noise

The output noise is measured with 10uF tantalum capacitor and 1.0uF ceramic capacitor across output.

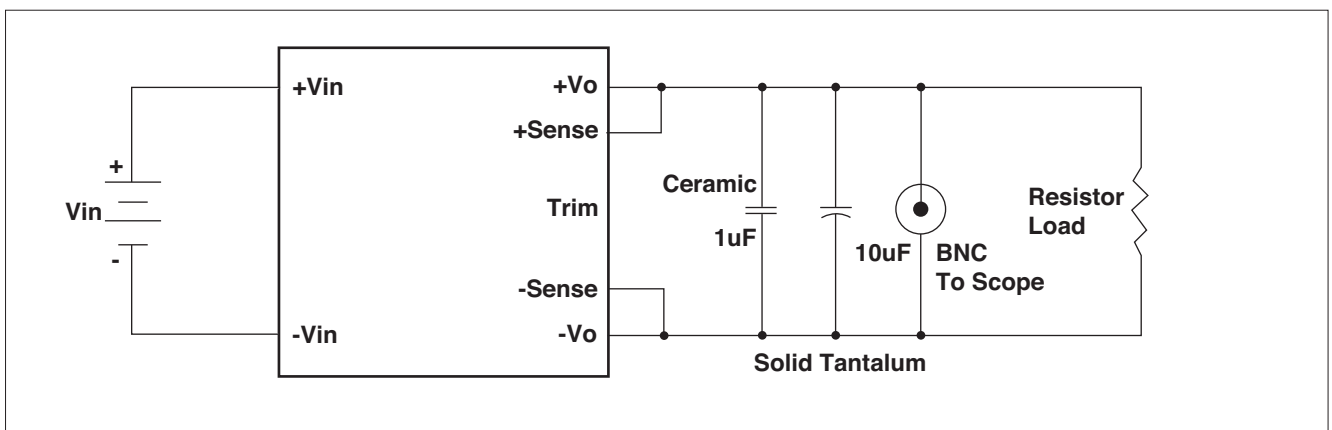

Output Ripple & Noise Test Circuit schematic

CHB50/50W/75/75W/100/150/Series Application Note

Power Derating:

The operating case temperature range of CHB series is -40°C to +100°C.

When operating the CHB series, proper de-rating or cooling is needed. The maximum case temperature under any operating condition should not exceed 100°C.

The following curve is the de-rating curve of CHB series without heat sink.

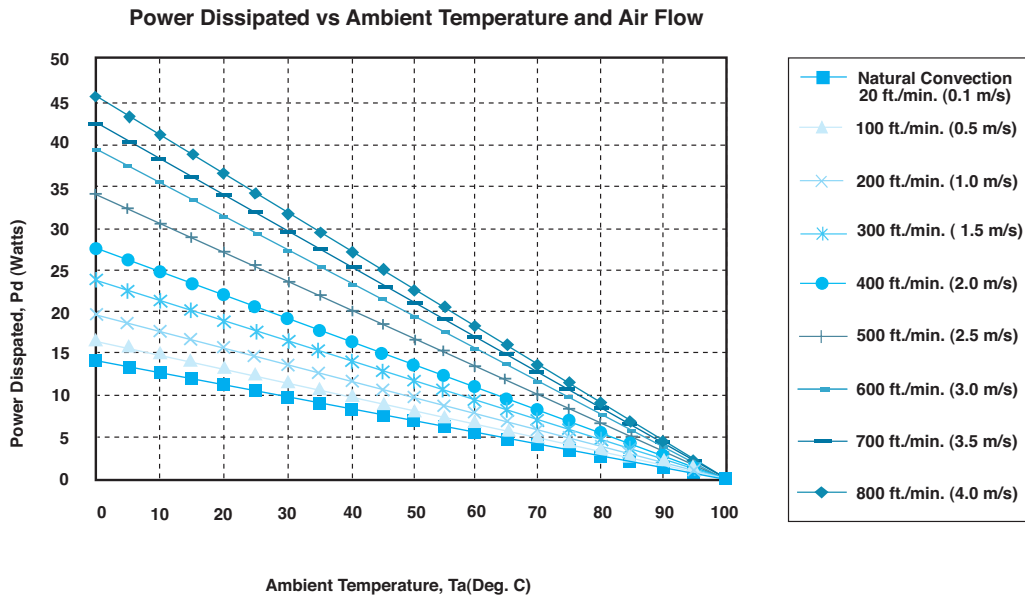

Forced Convection Power De-Rating with No Heat Sink

Example:

What is the minimum airflow necessary for a CHB75-48S12 operation at nominal line, an output current of 6.25A, and a maximum ambient temperature of 40°C

Solution:

Given: $V_{in}=48V_{dc}$, $V_o=12V_{dc}$, $I_o=6.25A$

Determine Power dissipation (Pd):

$$P_d = P_i - P_o = P_o(1 - \eta) / \eta$$

$$P_d = 12 \times 6.25 \times (1 - 0.85) / 0.85 = 13.24 \text{ Watts}$$

Determine airflow:

Given: $P_d=13.24W$ and $T_a=40^\circ C$

Check above Power de-rating curve:

Minimum airflow=300 ft./min.

Chart of Thermal Resistance vs Air Flow:

AIR FLOW RATE	TYPICAL R _{ca}
Natural Convection 20 ft./min. (0.1m/s)	7.12 °C/W
100 ft./min. (0.5m/s)	6.21 °C/W
200 ft./min. (1.0m/s)	5.17 °C/W
300 ft./min. (1.5m/s)	4.29 °C/W
400 ft./min. (2.0m/s)	3.64 °C/W
500 ft./min. (2.5m/s)	2.96 °C/W
600 ft./min. (3.0m/s)	2.53 °C/W
700 ft./min. (3.5m/s)	2.37 °C/W
800 ft./min. (4.0m/s)	2.19 °C/W

Verifying: The maximum temperature rise $\Delta T = P_d \times R_{ca} = 13.24 \times 4.29 = 56.8^\circ C$

The maximum case temperature $T_c = T_a + \Delta T = 96.8^\circ C < 100^\circ C$

Where: The R_{ca} is thermal resistance from case to ambience.

The T_a is ambient temperature and the T_c is case temperature.

<h2>Specifications</h2>	
INPUT SPECIFICATIONS:	
Input Voltage Range	110V 66-160V
Input Surge Voltage (100ms max.)	180Vdc max.
Under voltage lockout	power up 62V
	power down 56V
Positive Logic Remote ON/OFF:	
Logic Compatibility	Open Collector ref to -Input
Module ON	> 3.5Vdc to 75Vdc or Open Circuit
Module OFF	< 1.8Vdc
Input Filter	PI Type
OUTPUT SPECIFICATIONS:	
Voltage Accuracy:	±1.5% max.
Transient Response: 25% Step Load Change	
Error Band	±5% Vout
Recover Time	< 200µs
External Trim Adj. Range	±10%
Ripple & Noise, 20MHz BW(note 3)	
5V	40mV RMS, 100mV pk-pk max.
12V	60mV RMS, 150mV pk-pk max.
24V	100mV RMS, 240mV pk-pk max.
Temperature Coefficient	±0.03%/°C
Short Circuit Protection	Continuous
Line Regulation ¹	±0.2% max.
Load Regulation ²	±0.2% max.
Over Voltage Protection trip Range, % Vo nom.	115-140%
Current Limit	110% -180% Nominal Output
Start up time	45ms typ.
GENERAL SPECIFICATIONS:	
Efficiency	See Table
Isolation Voltage	Input/Output, Input/Case 2250VDC min.
	Output/Case 1500VDC min.
Isolation Resistance	107 ohm min.
Isolation Capacitance	1000pF typ.
Switching Frequency	200KHz typ.
Operating Case Temperature	-40°C to 100°C
Storage Temperature	-55°C to +105°C
Thermal Shutdown, Case Temp.	105°C typ.
Humidity	95% RH max. Non condensing
MTBF	MIL-HDBK-217F, GB, 25°C, Full Load TBD hrs typ.
Safety	UL60950-1 2 nd (Basic insulation)
EMC ⁷	EN50155(EN50121-3-2) with external filter
Shock/Vibration	meet EN50155(EN61373)
Environmental	meet EN50155(EN60068-2-1)
Dimensions	2.28x2.40x0.50 inches (57.9x61.0x12.7 mm)
Case Material	Aluminum Baseplate with Plastic Case
Weight	90g

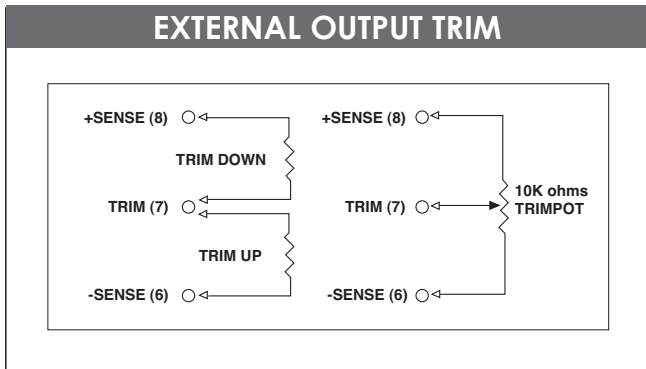
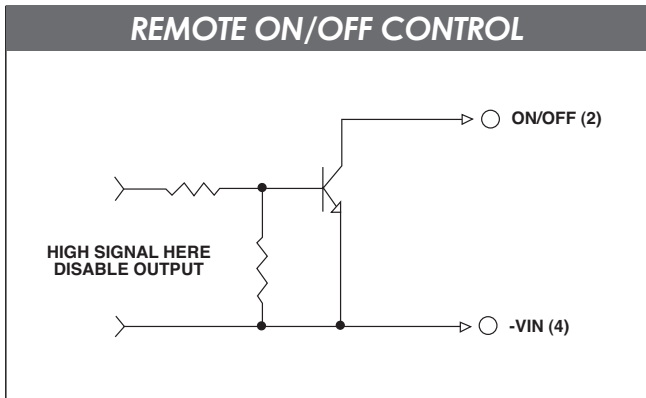

NOTE:

- Measured From High Line to Low Line
- Measured From Full Load to Zero Load
- Output Ripple and Noise measured with 10µF tantalum and 1µF ceramic capacitor across output
- Suffix "N" to the Model Number with Negative Logic Remote ON/OFF
 Module ON < 1.8Vdc
 Module OFF >3.5Vdc to 75Vdc or Open Circuit
- Suffix "-C" to the Model Number with Clear Mounting Insert (3.2mm DIA.)
- An external input capacitor 220µF for all models are recommended to reduce input ripple voltage.
- Design meet EN50155 and RIA12 refer to Application Note

CASE HB

All Dimensions In Inches(mm)
 Tolerance Inches: x.xx= ±0.02, x.xxx= ±0.010
 Millimeters: x.x= ±0.5, x.xx= ±0.25

Mounting Inserts M3*0.5 Through 4pl. **BOTTOM VIEW**

PIN CONNECTION	
<i>Pin</i>	<i>Function</i>
1	+V Input
2	ON/OFF
3	CASE
4	-V Input
5	-V Output
6	-Sense
7	Trim
8	+Sense
9	+V Output

All Specifications Typical At Nominal Line, Full Load and 25°C Unless Otherwise Noted.